



# JA90 DOME | TILED

## WHAT IS INCLUDED

- Refractory Cement Oven
- Reinforced Cement Base
- Stainless Steel or Black Powder Coated Flue & Cap
- Stainless Steel or Black PVD\* Arch & Slab Cover
- Black Powder Coated Oven Door
- Rendered or Tiled Finish (Mushroom Stone)
- Oven Stand/Stillage (Preassembled only)
- Assembly Instructions (DIY Kit only)
- 1 Year Warranty (Conditions Apply)



Mushroom Stone



All measurements may vary slightly

## EXTERNAL DIMENSIONS

Width (left to right)	1240mm
Length (front to back)	1400mm
Dome Height	770mm
Outer Arch Width	650mm
Outer Arch Height	355mm
Flue Base Width	470mm
Front Height	770mm
Front Width	1250mm
Dome Thickness	65mm
Insulation   Render Thickness	70-100mm
Rendered Oven Weight	920kg
Tiled Oven Weight	985kg

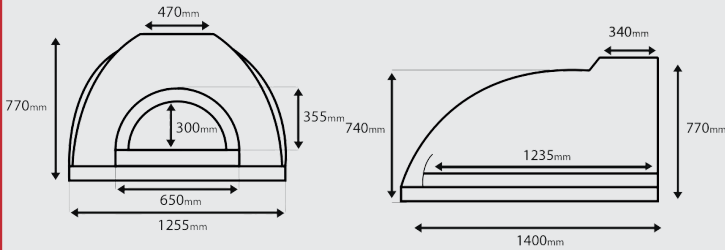

## INTERNAL DIMENSIONS

Width (left to right)	930mm
Length (front to back)	1235mm
Dome Height	470mm
Inner Arch Width	600mm
Inner Arch Height	300mm
Floor Brick Thickness	38mm

## INTERNAL COOKING AREA

Width (left to right)	930mm
Length (front to back)	900mm

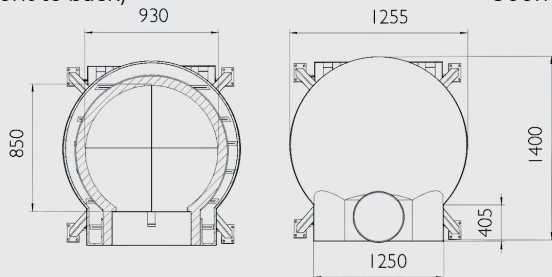

## FLUE DIMENSIONS

Flue Height	1000mm
Flue Diameter	150mm
Flue Cap Diameter	275mm

## BENCHTOP LAYOUT

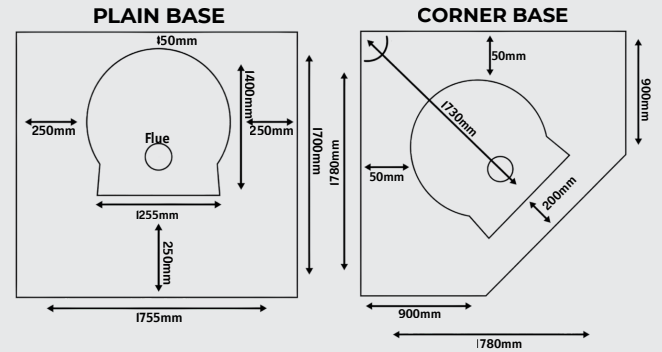

Suggested Base Height	900-1000mm	900-1000mm
Suggested Slab Thickness		75mm
Suggested Distance from Walls		50mm
Suggested Front Prep Area		200-250mm

## STAND/STILLAGE DIMENSIONS

Width (left to right)	1330mm
Length (front to back)	1630mm
Height (excluding wheels)	975mm
Stand Weight	65kg
Wheel Height	134mm
Wheel Weight	3kg
Rendered Oven and Stand Weight	985kg
Tiled Oven and Stand Weight	1050kg



## DIY PRECAST KIT

Box Width (left to right)	1140mm
Box Length (front to back)	1180mm
Box Height	960mm
Box Weight - includes kit	400kg
Number of Dome Pieces	4
Weight of Dome Pieces	129kg   97kg   60kg   10kg
Stand / Stillage not included with precast kits	



## OPTIONAL EXTRAS

<b>PIZZA OVEN COVER</b>	
Weight	2kg



\*PVD - Physical Vapor Deposition is a metal coating, it is a thin-film coating process where a solid material is vaporized in a vacuum and deposited onto a surface to enhance its properties. This process creates a highly durable, corrosion-resistant, and aesthetically pleasing finish on various materials.

© January 2026 All rights reserved.